

# FM-60

## SPECIFICATIONS

### BASE SHEET TO LIGHTWEIGHT INSULATING CONCRETE AND VARIOUS GYPSUM ROOFDECKS

#### COMPOSITION

**Fastener:** Precision formed from polymer coated steel to prevent corrosion. Rectangular dual gripping legs, 1.7" long.

#### TECHNICAL DATA

**Approvals:** FM-60 fasteners maintain Factory Mutual and Underwriters Lab Approvals.

**Fastening Pattern:** Consult Factory Mutual or Underwriters Lab requirements for recommended pattern in normal, exposed, and hurricane areas.

**Field Testing:** On-site withdrawal testing should always be performed to evaluate the ability of the roofing substrate to satisfactorily accept and retain fasteners. Such testing may alter fastener selection and modify applicable fastening patterns.

#### INSTALLATION

**Equipment:** Always use the ES Magnetic Driver to assure proper fastener installation.

**Method:** Drive FM-60 as an ordinary nail. DO NOT TOE. Seat cap flush with roofing surface (see illustration).

**Operation:** As FM-60 is driven, dual legs diverge and cut a plug of deck material that wedge and anchor the FM-60 in its own hole. No pre-drilling is required.

**Availability:** FM-60 is a proprietary product manufactured only by ES Products, Inc. and distributed by leading roofing material and equipment wholesalers throughout the United States.

**Packaging:** 3,000 FM-60 fasteners per carton. Gross weight: 57 lbs. Shrink wrapped and palletized.

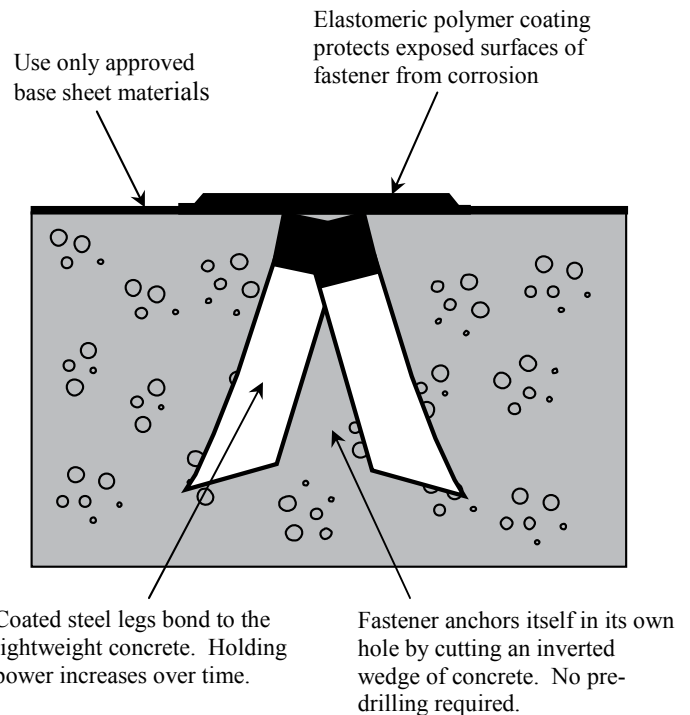
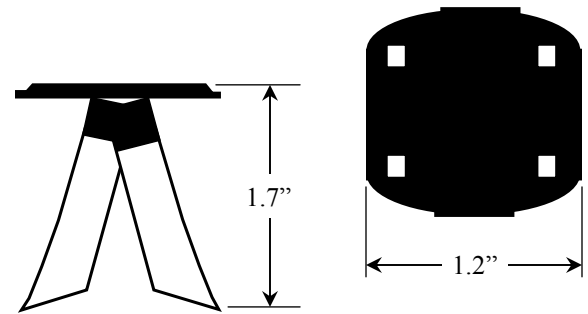

#### PROUDLY MADE IN THE U.S.A.

**Warranty:** ES Products, Inc. warrants its products for one year from date of sale against defective workmanship and material, and its liability therefore shall be limited to replacing defective products reported defective during the warranty period. ES Products is not responsible for any failure attributable to improper use or installation in any manner inconsistent with manufacturer's specifications. THIS WARRANTY IS IN LIEU OF ANY OTHER WARRANTY, EXPRESS OR IMPLIED, ALL OF WHICH ARE EXPRESSLY DISCLAIMED INCLUDING ANY WARRANTY OF MERCHANTABILITY AND ANY WARRANTY OF FITNESS FOR PARTICULAR USE. This warranty provides specific legal rights and remedies that may vary from state to state.



# ESPRODUCTS

280 Franklin Street • Bristol, RI 02809  
800-493-ROOF (7663) • esproducts.com

# FM-45

## SPECIFICATIONS

BASE SHEET TO HIGHER DENSITY  
LIGHTWEIGHT INSULATING CONCRETE,  
NVS, AND VARIOUS GYPSUM ROOFDECKS

### COMPOSITION

**Fastener:** Precision formed from polymer coated steel to prevent corrosion. Rectangular dual gripping legs, 1.2" long.

### TECHNICAL DATA

**Approvals:** FM-45 fasteners maintain Factory Mutual and Underwriters Lab Approvals.

**Fastening Pattern:** Consult Factory Mutual or Underwriters Lab requirements for recommended pattern in normal, exposed, and hurricane areas.

**Field Testing:** On-site withdrawal testing should always be performed to evaluate the ability of the roofing substrate to satisfactorily accept and retain fasteners. Such testing may alter fastener selection and modify applicable fastening patterns.

### INSTALLATION

**Equipment:** Always use the ES Magnetic Driver to assure proper fastener installation.

**Method:** Drive FM-45 as an ordinary nail. DO NOT TOE. Seat cap flush with roofing surface (see illustration).

**Operation:** As FM-45 is driven, dual legs diverge and cut a plug of deck material that wedge and anchor the FM-45 in its own hole. No pre-drilling is required.

**Availability:** FM-45 is a proprietary product manufactured only by ES Products, Inc. and distributed by leading roofing material and equipment wholesalers throughout the United States.

**Packaging:** 3,000 FM-45 fasteners per carton. Gross weight: 53 lbs. Shrink wrapped and palletized.

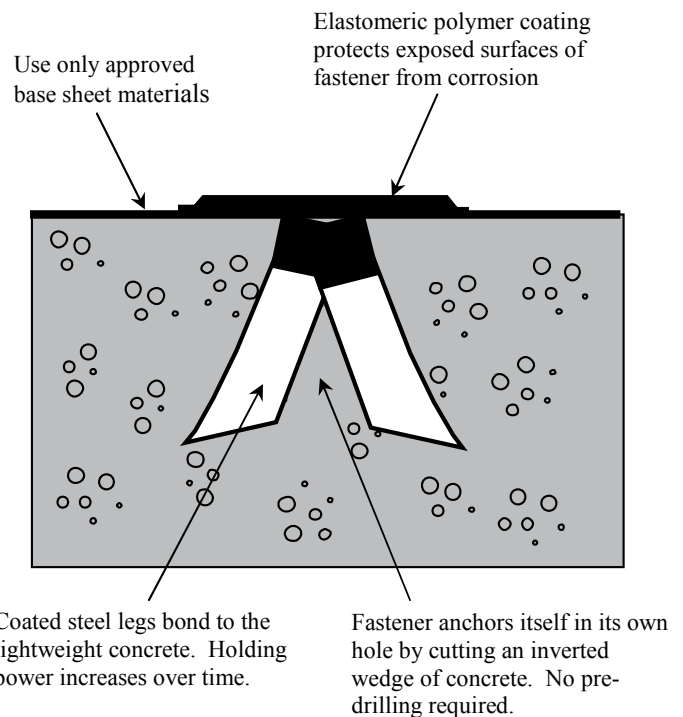
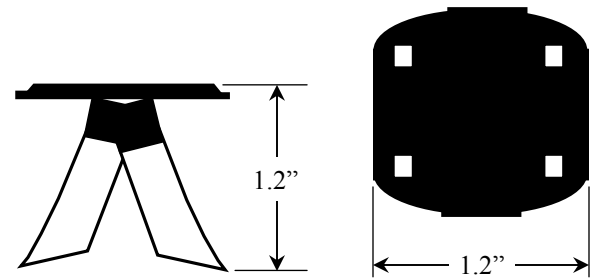

### PROUDLY MADE IN THE U.S.A.

**Warranty:** ES Products, Inc. warrants its products for one year from date of sale against defective workmanship and material, and its liability therefore shall be limited to replacing defective products reported defective during the warranty period. ES Products is not responsible for any failure attributable to improper use or installation in any manner inconsistent with manufacturer's specifications. THIS WARRANTY IS IN LIEU OF ANY OTHER WARRANTY, EXPRESS OR IMPLIED, ALL OF WHICH ARE EXPRESSLY DISCLAIMED INCLUDING ANY WARRANTY OF MERCHANTABILITY AND ANY WARRANTY OF FITNESS FOR PARTICULAR USE. This warranty provides specific legal rights and remedies that may vary from state to state.



# ESPRODUCTS

280 Franklin Street • Bristol, RI 02809  
800-493-ROOF (7663) • esproducts.com